

PAYCHECK® NEXTGEN™

PayCheck® NextGen™ Rev 1
PayCheck® NextGen™ Rev 2

Service Manual



March 25, 2024
Document # 720009-0001R

Legal Notices

Disclaimer

Information in this document is subject to change without notice. Consult your Nanoptix Inc. sales representative for information that is applicable and current. Nanoptix Inc. reserves the right to improve products as new technology, components, software and firmware become available.

No part of this document may be reproduced or transmitted in any form or by any means, electronic or mechanical, for any purpose without the express written permission of Nanoptix Inc.

Copyright

Copyright 2023 by Nanoptix Inc.
Dieppe, New Brunswick Canada
All rights reserved
Printed in Canada
Confidential, Unpublished
Property of Nanoptix Inc.

Trademarks

Epson is a registered trademark of Epson Corporation.

Windows is a registered trademark of Microsoft Corporation.

Nanoptix is a trademark. Other trademarks and registered trademarks are the property of their respective holders.

Federal Communications Commission (FCC) Radio Frequency Interference Statement

Warning

Changes or modifications to this unit not expressly approved by the party responsible for compliance could void the user's authority to operate the equipment.

Note

This equipment has been tested and found to comply with the limits for a Class B digital device, pursuant to Part 15 of the FCC Rules. These limits are designed to provide reasonable protection against harmful interference when the equipment is operated in a commercial environment. This equipment generates, uses, and can radiate radio frequency energy and, if not installed and used in accordance with the instruction manual, may cause harmful interference to radio communications. Operation of this equipment in a residential area is likely to cause harmful interference in which case the user will be required to correct the interference at his own expense.

Information to the User

This equipment must be installed and used in strict accordance with the manufacturer's instructions. However, there is no guarantee that interference to radio communications will not occur in a particular commercial installation. If this equipment does cause interference, which can be determined by turning the equipment off and on, the user is encouraged to contact Nanoptix Inc. immediately.

Nanoptix Inc. is not responsible for any radio or television interference caused by unauthorized modification of this equipment or the substitution or attachment of connecting cables and equipment other than those specified by Nanoptix Inc. The correction of interferences caused by such unauthorized modification, substitution or attachment will be the responsibility of the user.

In order to ensure compliance with the Product Safety, FCC and CE marking requirements, you must use the power supply, power cord, and interface cable, which were shipped with this product or which meet the following parameters:

Power Supply

UL Listed power supply with standard 60Hz-50Hz, 100-240VAC input and 24VDC output equipped with AC line filtering, over-current and short-circuit protection.

Use of this product with a power supply other than the Nanoptix Inc. power supply will require you to test the power supply and Nanoptix Inc. printer for FCC and CE mark certification.

Communication Interface Cable

An approved Nanoptix interface cable must be used with this product. Use of a cable other than Nanoptix approved product will require that you test the cable with the Nanoptix Inc. printer and your system for FCC and CE mark certification.

Power Cord

A UL listed, detachable power cord must be used. A power cord with Type SVT marking must be used. For applications outside North America, power cords that meet the particular country's certification and application requirements should be used.

Use of a power cord other than described here may result in a violation of safety certifications that is in force in the country of use.

Industry Canada (IC)

Radio Frequency Interference Statement

This Class B digital apparatus meets all requirements of the Canadian Interference-Causing Equipment Regulations.

Cet appareil numérique de la classe B respecte toutes les exigences du Règlement sur le matériel brouilleur du Canada.

Change and Review History

Revision	Editor	Date	Changes
1	G. Robichaud	2017-10-18	Initial version
2	Z. Wheeler	2022-10-27	Added duty cycle information
3	G. Robichaud	2023-04-06	Revised pictures of paper low
4	G. Robichaud	2024-03-25	Amended for Rev 2 changes

Table of Contents

<i>About the Printer</i>	<i>1</i>
1.1 Description of Printer	1
1.2 General specifications	2
1.3 Revision Identification	4
1.4 Duty Cycle limit.....	4
1.5 Paper Loading	5
1.6 Printer Interface.....	7
1.7 Printer Controls	9
1.7.1 Printer Reset (Service use only).....	9
1.7.2 Paper Feed Button	9
1.7.3 DIP switches	10
1.7.4 LED.....	11
1.7.5 Paper Low	12
1.8 Testing the Printer	13
1.8.1 Configuration Ticket.....	13
1.8.2 Printer Performance Metrics.....	14
1.9 Clearing Jams.....	15
<i>2 Troubleshooting the Printer</i>	<i>16</i>
2.1 Basic Printer Operation.....	16
2.2 Communication Cables Pin-Out.....	17
2.2.1 Universal Communication interface	17
2.2.2 Illuminated bezel interface.....	17
2.3 Printing Problems	18
2.3.1 Main Controller PCB Connector Layout	19
<i>3 Media and Supplies Guide</i>	<i>20</i>
3.1 Thermal Paper Specifications	20
3.2 Ordering Thermal Paper.....	22
3.3 Ordering supplies & cables	22
3.4 Parts List (Available as a separate document)	23
3.5 Exploded View (Available as a separate document)	24
3.6 Mechanical Drawings	25
<i>4 Spare parts replacement instructions</i>	<i>27</i>
<i>5 Printer Maintenance Instructions</i>	<i>33</i>
<i>6 Service & Support</i>	<i>36</i>
6.1 Returning printers back to Nanoptix for repairs (RMA).....	36
6.2 Technical Support Contact Information.....	36

Figures

FIGURE 1: NANOPTIX PAYCHECK® NEXTGEN™ PRINTER.....	1
FIGURE 2: NAME PLATE	4
FIGURE 2: DUTY CYCLE LIMIT	4
FIGURE 3: TICKET STACK ORIENTATION	5
FIGURE 4: LOADING PAPER	6
FIGURE 5: INTERFACE – LEFT	7
FIGURE 7: INTERFACE – RIGHT	8
FIGURE 6: INTERFACE - FRONT	8
FIGURE 7: PRINTER RESET	9
FIGURE 8: PAPER FEED BUTTON.....	9
FIGURE 9: DIP SWITCH.....	10
FIGURE 10: DIP SWITCH.....	10
FIGURE 11: LED POSITIONS	11
FIGURE 12: PAPER LOW.....	12
FIGURE 13: SAMPLE TEST TICKET.....	13
FIGURE 14: SAMPLE METRICS TICKET	14
FIGURE 15: CLEARING JAMS.....	15
FIGURE 16: SENSORS	16
FIGURE 17: CONNECTOR LAYOUT (REV 2 SHOWN).....	19
FIGURE 18: PERFORATION TEST	20
FIGURE 19: TICKET SPECIFICATIONS	21
FIGURE 20: PART LIST.....	23
FIGURE 21: EXPLODED VIEW	24
FIGURE 22: DIMENSIONS - FRONT	25
FIGURE 23: DIMENSIONS - BOTTOM.....	25
FIGURE 24: DIMENSIONS – RIGHT SIDE (NO TICKET EXTENSION).....	26
FIGURE 25: DIMENSIONS – RIGHT SIDE (600 TICKET EXTENSION)	26
FIGURE 26: DIMENSIONS – RIGHT SIDE (800 TICKET EXTENSION)	26
FIGURE 27: PRINTER MOUNT	27
FIGURE 28: JAM PROOF MODULE	27
FIGURE 29: BASE PLATE	28
FIGURE 30: CIRCUIT BOARDS	28
FIGURE 31: TICKET INLET & INDEX SENSOR	29
FIGURE 32: TICKET TRAY	29
FIGURE 33: FRONT BAR	30
FIGURE 34: PRINTING MECH	30
FIGURE 35: PAPER GUIDE	31
FIGURE 36: TOP PAPER GUIDE	31
FIGURE 37: CHUTE SENSOR	32
FIGURE 38: GUIDE SWITCH.....	32
FIGURE 39: REMOVE EXCESS DUST	33
FIGURE 40: REMOVE TOP PAPER GUIDE	33
FIGURE 41: REMOVE ROLLER	34
FIGURE 42: CLEAN ROLLER.....	34
FIGURE 43: CLEAN PAPER GUIDE SENSOR USING A COTTON SWAB.....	34
FIGURE 44: CLEAN HEATING ELEMENTS.....	35

Tables

TABLE 1: SPECIFICATIONS	3
TABLE 2: REVISION	4
TABLE 2: INTERFACE - LEFT	7
TABLE 4: INTERFACE - RIGHT	8
TABLE 3: INTERFACE – FRONT	8
TABLE 4: LED INFORMATION	11
TABLE 5: PAPER LOW	12
TABLE 6: BEZEL INTERFACE	16
TABLE 7: 14 PIN RS232 SERIAL INTERFACE	17
TABLE 8: BEZEL INTERFACE	17
TABLE 9: TROUBLESHOOTING PRINTING PROBLEMS	18
TABLE 10: CONNECTOR FUNCTIONS	19
TABLE 11: PAPER SPECIFICATIONS	20
TABLE 12: ORDERING THERMAL PAPER	22
TABLE 13: ORDERING SUPPLIES	22

About the Printer

1.1 Description of Printer

The Nanoptix PayCheck® NextGen™ is extremely fast, quiet, and very reliable. With thermal printing technology, there is no ribbon cassette to change, and paper loading is extremely simple. The printer is small enough to fit almost anywhere and is easy to use with the ticket exiting from the front.



Figure 1: Nanoptix PayCheck® NextGen™ Printer

1.2 General specifications

Print Method	Direct Thermal
Resolution	8 dot/mm (203 dpi)
Print Width	64mm
Paper Width	65mm
Cartridge Size	400, 600, 800
Operating Temperature	0° to 50° C
Storage Temperature	-20° C to 75° C
Operating Relative Humidity	5% to 90% RH at 50°C (non-condensing)
Communication Interface Options	2 Bidirectional RS-232C Micro SD Card Reader 2 USB 2.0 high-speed device ports HDMI output port, 720p (Rev 1 only) Ethernet Port (optional) USB 2.0 high-speed host ports (3 on Rev 1, 1 on Rev 2)
Memory/Firmware	32 Gbit Flash, 4 Gbit Ram & 16 kbit EEPROM
Resident Character Sets	Support 32 fonts Approx. (16 resident 16 user defined)
Integrated Bar Codes	UPC-A, UPC-E, Interleaved 2 of 5, Code 39, Code 93, Codabar, EAN 8, EAN 13, Code 128. Note: other barcodes can be programmed quickly
Speed	Up to 200 mm (7.9 in.) per sec. (monochrome) Up to 125 mm (5 in.) per sec. (two-color mode)
Sensors	Last sheet paper low, adjustable paper low, paper out, ticket taken, drawer open, cover open, ticket jam
Duty Cycle (max.)	5 tickets per minute
Human Interface	Drop-in paper loading, status LEDs, paper feed button
Dimensions	113mm width x 67mm height x 285mm depth without anti-jam: 255mm depth
Weight	0.665 Kg (1.465 lbs) without anti-jam: 0.610 Kg (1.350 lbs)

Immunity	EN 55024 Information Technology Equipment
Emission Standards	<i>EN 55032:2015/A11:2020</i> <i>CISPR 32:2015/AMD1:2019</i> <i>AS/NZS CISPR 32: 2015 AMD 1:2020</i> <i>EN 61000-3-2:2014</i> <i>EN 61000-3-3:2013</i> <i>FCC 47 CFR Part 15, Subpart B - Verification</i> <i>ICES-003 Issue 7 October 2020</i> <i>EN 55035:2017/A11:2020</i> <i>CISPR 35:2016</i>
Safety	QPS Certified Control Number: LR1123

Table 1: Specifications

1.3 Revision Identification

There are 2 versions of the Nanoptix PayCheck® NextGen™ printer, PayCheck® NextGen™ revision 1 and PayCheck® NextGen™ revision 2. The revision is identified by the product serial number located on the name plate.



Figure 2: Name plate

Product serial number	PayCheck® NextGen™ revision number
NGXXXXX	Revision 1
NAXXXXX	Revision 2

Table 2: Revision

1.4 Duty Cycle limit

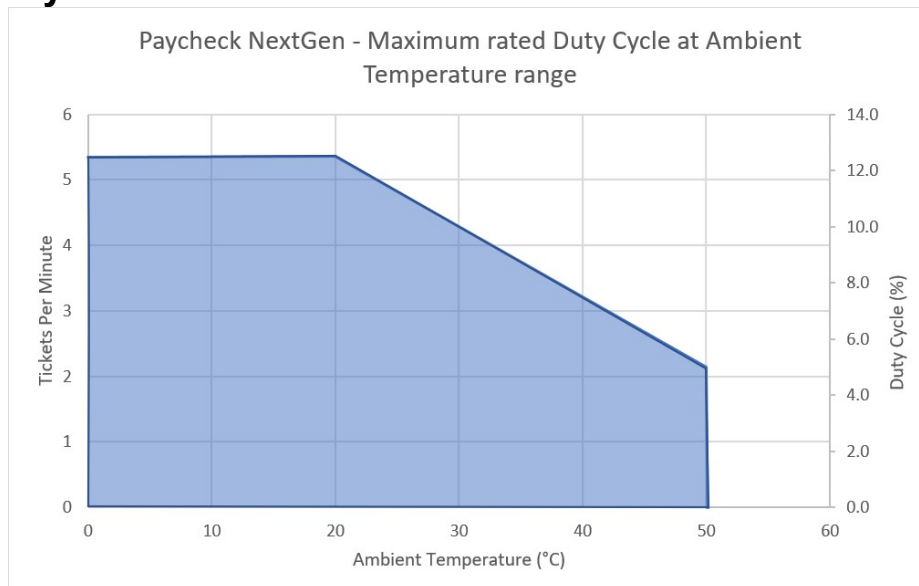

Figure 3: Duty Cycle Limit

1.5 Paper Loading

The paper stack should be changed when it is low or out.

Caution: The printer will not operate without paper, but it may continue to accept data from the host computer. Since the printer cannot print any transactions, the data may be lost.

The maximum stack that will fit in the ticket cartridge is 400, 600 or 800 tickets depending on the cartridge option that was purchased with the printer.

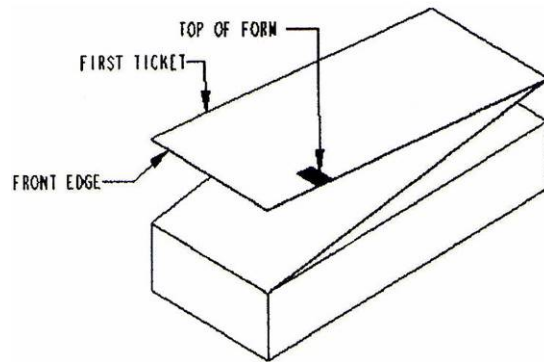

Ticket stack orientation:
The stack must be oriented so that its top of form mark is on the leading edge of the ticket.

Figure 4: Ticket Stack Orientation

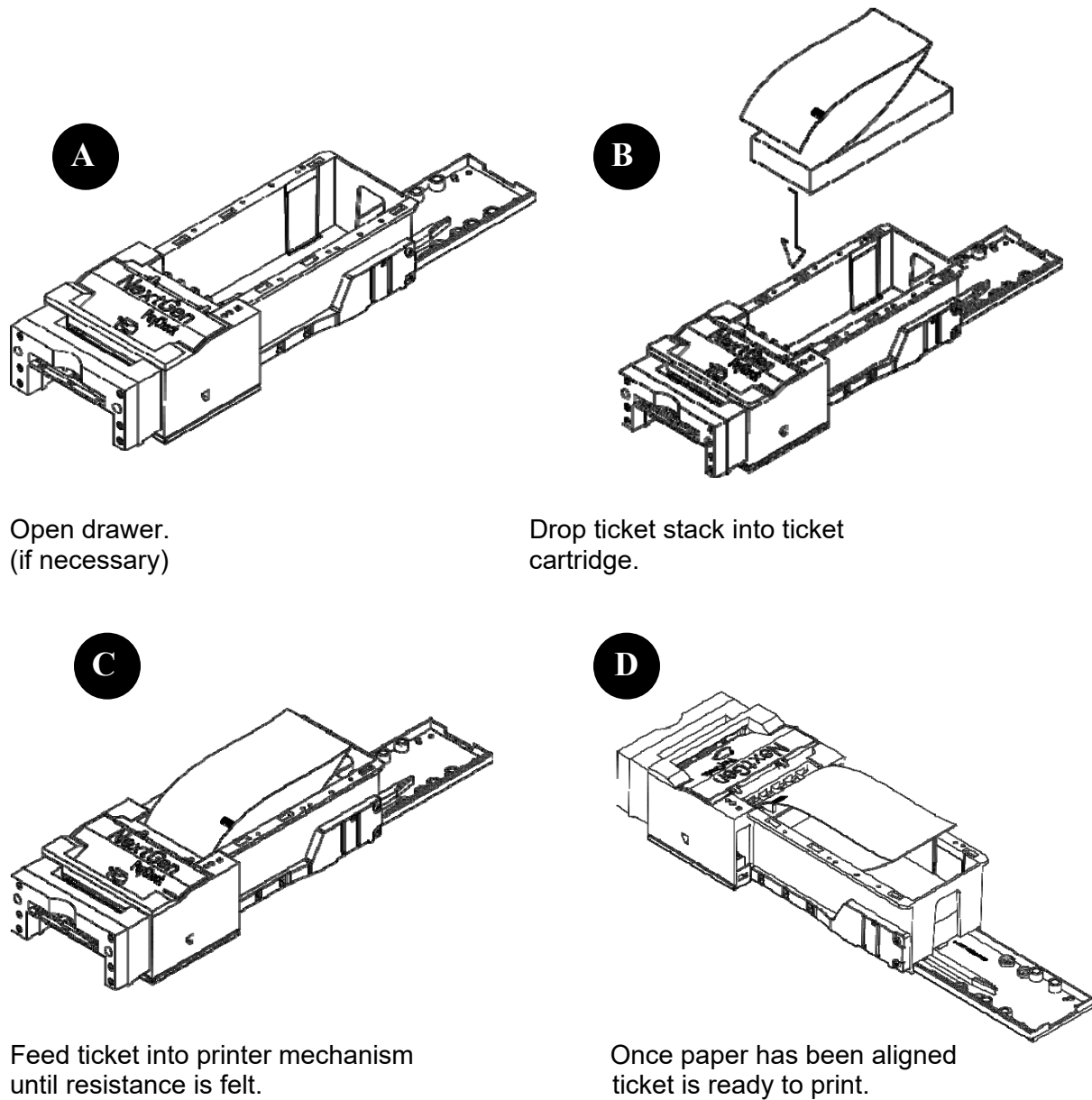

Figure 5: Loading Paper

1.6 Printer Interface

Identifier	Type	Function
A	USB type B	USB communication
B	14 pin "Molex mini fit"	Power & dual serial communication
C	Left jumper	Connects pin 5 to Pin 7 & 10 on port B (Rev 1 only)
	Right jumper	Bezel control connected to pin 9 of port B (Rev 1 only)
D	Switch left position	Port B Aux port Netplex (Rev 1 only)
	Switch right position	Port B Aux port RS232 (Rev 1 only)
E	3 pin "JST PE"	Debug

Note: For ESD protection, the left jumper must be installed when switch D is set to Netplex

Table 3: Interface - left

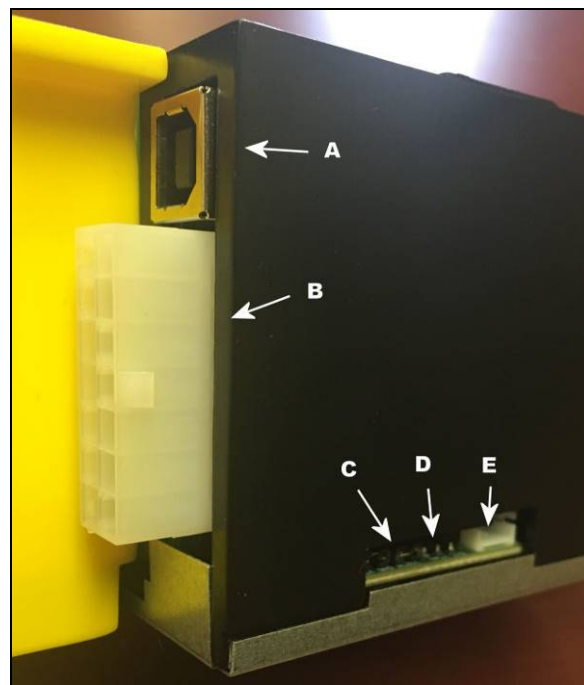

Figure 6: Interface – left

Identifier	Type	Function
F	USB type A	USB communication (Rev 1 only)
G	RJ45	802.3 Network interface (optional)
H	Micro HDMI	Video, etc. (Rev 1 only)

Table 4: Interface - right



Figure 7: Interface – right

Identifier	Type	Function
I	SD media card interface	MicroSD
J	Molex microfit 3.0	Bezel illumination
K	Mini USB type B	maintenance
L	USB type A	USB communication (expansion)

Table 5: Interface – front

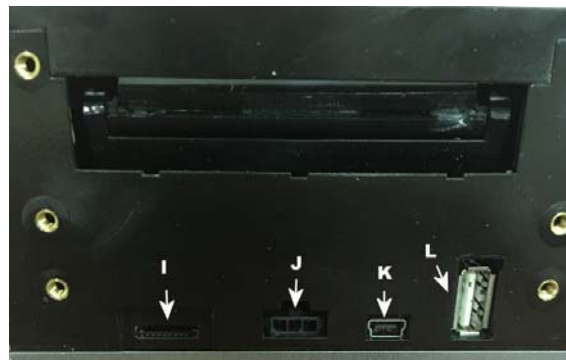

Figure 8: Interface - front

1.7 Printer Controls

1.7.1 Printer Reset (Service use only)

The printer is reset by disconnecting and reconnecting the power/communication cable. Once connected, the printer goes through a startup routine and resets itself.

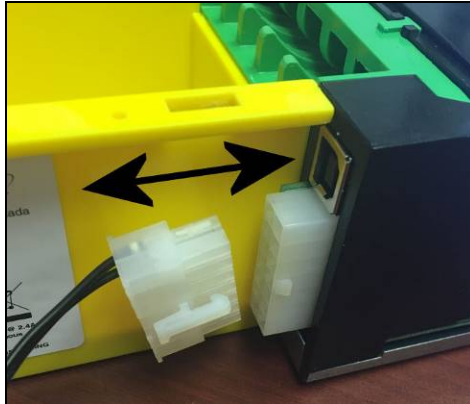

Figure 9: Printer Reset

1.7.2 Paper Feed Button

The paper feed button is used to advance the paper. Once the ticket removed, the printer will realign the paper to the ready position.



Figure 10: Paper Feed Button

1.7.3 DIP switches

The DIP switch is available through the access hole of the bottom plate.

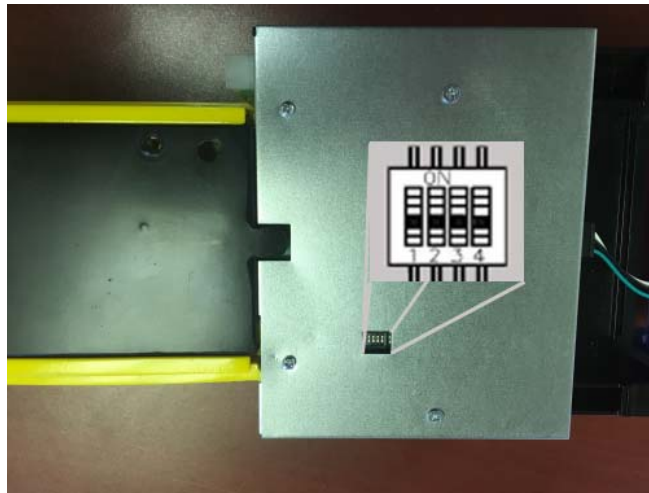

Figure 11: DIP Switch

Identifier	Position	Function
1	ON	Recovery mode
	OFF (default)	Run mode
2	ON or OFF (default)	Spare
3	ON or OFF (default)	Spare
4	ON (default)	Watchdog enabled
	OFF	Watchdog disabled

Figure 12: DIP Switch

1.7.4 LED

Two LEDs provide visual feedback of the operation of the printer.



Figure 13: LED Positions

Error LED (Red)	Status LED (Green)	Condition
OFF	ON	Printer Ready
ON	OFF	Paper Out
MED BLINK	OFF	Temperature Error
SLOW BLINK	OFF	Voltage Error (Over 26.2 VDC)
FAST BLINK	ON	Print Head Error
FAST BLINK	ON	Missing Black Index Mark
FAST BLINK	ON	Paper Jam

Table 6: LED Information

1.7.5 Paper Low

There are 4 paper low detection options. Paper low sensor 1 is only used when paper low sensor 2 is in the off position.

Detection quantity (sheets)	Paper low 2 position
1	OFF
50	HIGH
35	MEDIUM
15	LOW

Table 7: Paper low

To change the paper low detection quantity. Turn the printer on its left side and remove the sensor cover. Using the alignment pins, place the sensor in the desired position. Then reinstall the sensor cover

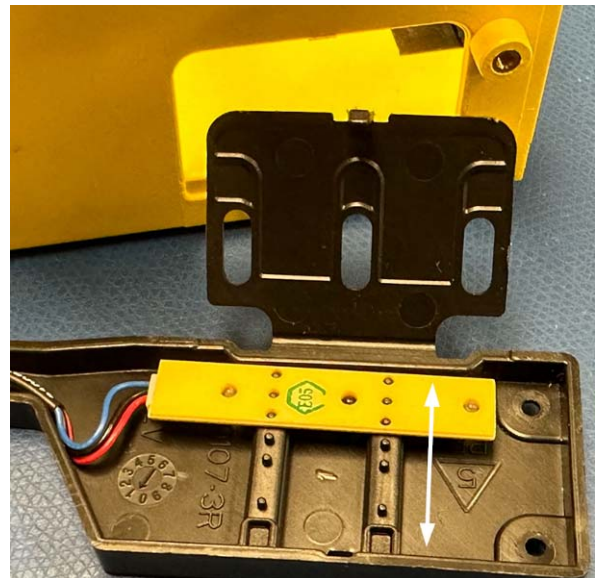
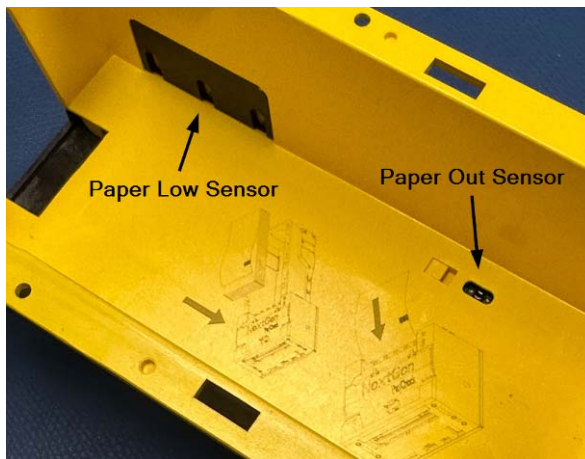

Figure 14: Paper low

1.8 Testing the Printer

1.8.1 Configuration Ticket

This test can be used to verify the correct operation of the printer. The test prints a resident ticket listing the current printer settings. This ticket can also be used to verify printing quality. To print the test ticket, the printer must be powered "ON" while holding the paper feed button for approximately 5 seconds. A status ticket similar to below will be printed. Pressing the button again will result in blank tickets.

```

Model:                               PayCheck® NextGen™
Firmware:                             NPG-9.99Z (0x6D00)
Printer Driver Ver:                     1.0.1.1
SETTINGS
COMMUNICATION
  Protocol:                             NTL
  Interface:                             Serial
  Serila Settings:                       9600,8,NONE
  Handshaking:                           XON + RTS
  Print mode:                             Page
NETWORKING
  eth0                                   99.99.99.201
PRINT CONTROL
  Speed:                                 200 mm/sec
  BurnTime:                              300 uS
  Motor Current:                          58%
PRINTER ENVIRONMENTAL CONDITIONS
  Voltage:                                24.7 Volts
  Temperature:                            25 Celcius
SYSTEM RESOURCES
  FLASH Used=00000
  Free=65535
LIBRARY INVENTORY (Satandard)
  Tpl: 0, 1, 2, 4, 4, 5,6,7,8,9,A,B
  Rgn 1, 2, 3, 4, 5, 6, 7, 8, h, 9, A, B, C, D, E, F,
      G, I, J, K, L, N, O, P, Q, R, S, T, U, Z, X, a,
      b, c, d, e, f, g, I, j, k, l, m, n, o, p, q
  Gfx:
LIBRARY INFORMATION
  Board:                                 209022-0001R-04
  Board ID:                              5P00122
  Printer ID:                             NG0003C
  Date Code:                              20160505

*S|0|PAY-4.82H|@|@|@|@|@|P|*
    
```

Figure 15: Sample Test Ticket

1.8.2 Printer Performance Metrics

(not implemented in all firmware versions)

This ticket lists the performance metrics recorded by the printer since the printer was installed. The test prints a resident ticket listing various errors and status. To print this ticket, the printer must be turned "ON" and operating in normal "Run Mode". Press and hold the paper feed button for approximately 5 seconds. A performance ticket similar to below will be printed.

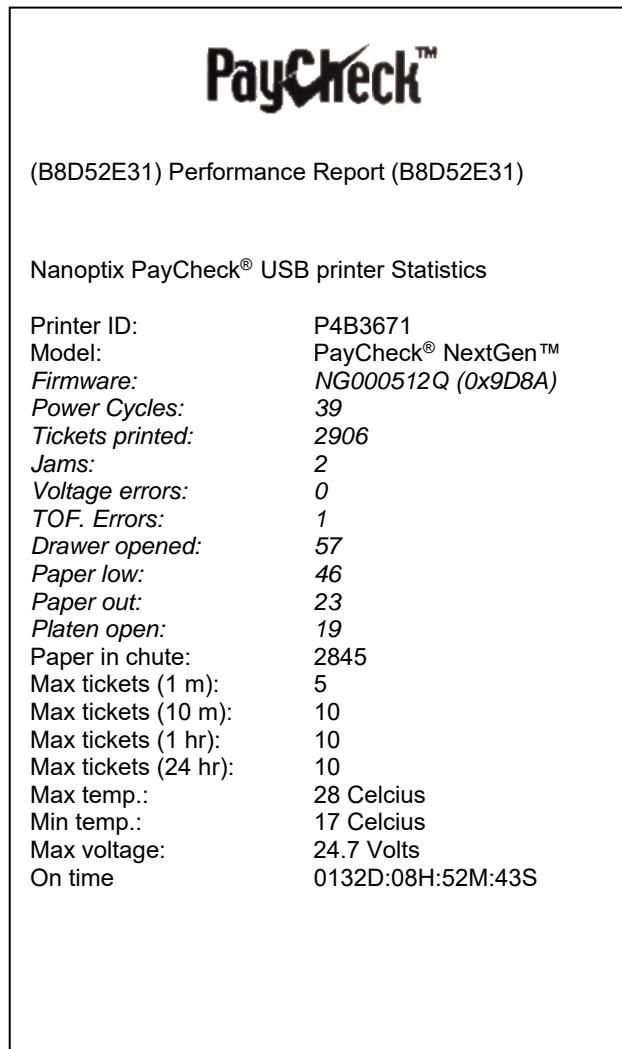

Figure 16: Sample Metrics Ticket

1.9 Clearing Jams

The Nanoptix PayCheck[®] NextGen[™] printer's paper guide and printing mechanism roller are easily removed, giving full access to the paper path.

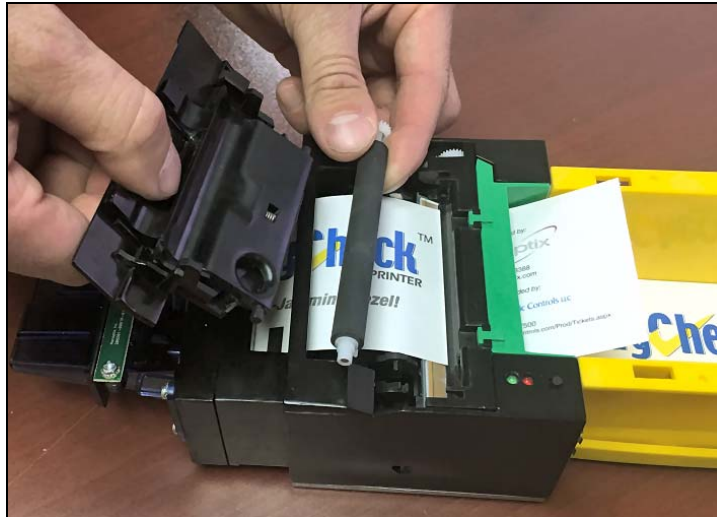

Figure 17: Clearing Jams

2 Troubleshooting the Printer

2.1 Basic Printer Operation

Although the Nanoptix PayCheck® printer is a complex device, its operation is fairly simple. The printer requires two consumables to operate, (1) a regulated 24 VDC power source and (2) approved thermal paper. The printer is equipped with eight communication interface ports.

The printer is mounted using a sliding baseplate. This baseplate's home position is detected by a magnetic sensor. A reflective optical sensor (B) situated in the bottom of the ticket tray is used to detect the last sheet of paper. In order to do this, the paper low sensor (C) must be installed in "disable" position. This paper low sensor (C) has 3 other mounting positions used to trigger a paper low condition at varying amounts of paper left in the tray. A third optical sensor (F) is used in the printing mechanism assembly to detect the presence of paper and start the feeder motor when loading paper. This sensor also works in conjunction with a fourth optical sensor (A) situated in the paper chute to realign paper back to its "ready" position.

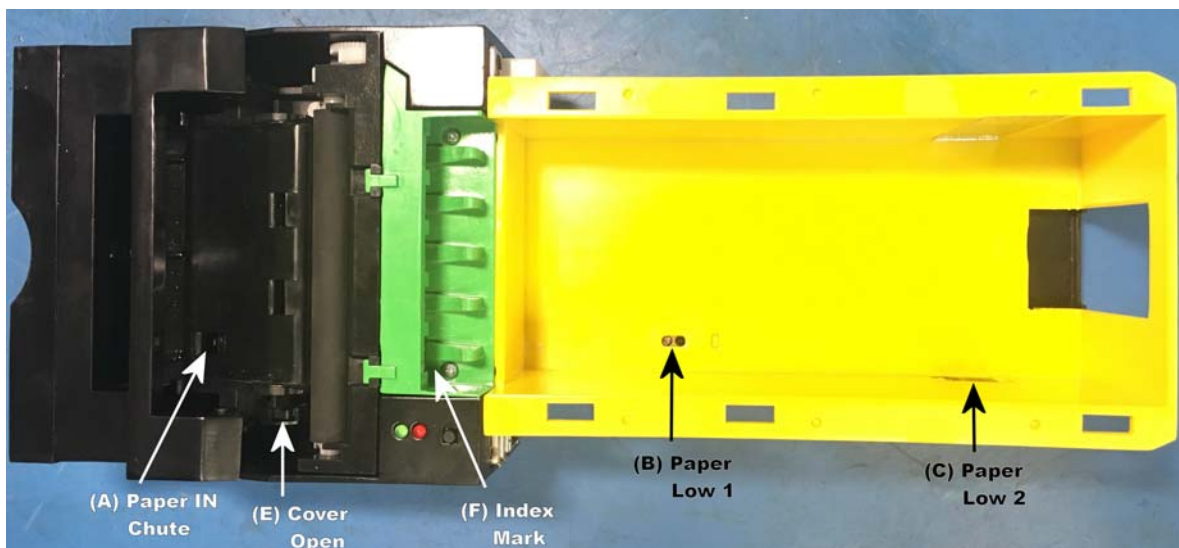

Figure 18: Sensors

Identifier	Function
A	Paper in chute
B	Paper low 1 (single sheet)
C	Paper low 2 (3 height options)
D	Printer closed (under bracket)
E	Cover open
F	Index (Top of form)

Table 8: Bezel Interface

2.2 Communication Cables Pin-Out

2.2.1 Universal Communication interface

The table below describes the connection pin-out for the Universal Interface (14-pin “Molex” type)

Pin	Signal Name	Printer I/O	Host I/O	Printer Function
1	Reset	Input	Output	Resets Printer
2	PRT_AUX_RXD	Input	Output	Auxiliary Receive
3	VAUX	Input	Output	Auxiliary Power
4	PRT_AUX_TXD	Output	Input	Auxiliary Transmit
5	AUX_Ground (See note 1)	Signal / Frame Ground	Signal / Frame Ground	Signal / Frame Ground
6	24V	Power Input	n/a	Power Input
7	Signal / Frame Ground	Signal / Frame Ground	Signal / Frame Ground	Signal / Frame Ground
8	24V	Power Input	n/a	Power Input
9	Bezel_pwm (See note 2)	24V Output	n/a	Bezel Driver
10	Signal / Frame Ground	Signal / Frame Ground	Signal/ Frame Ground	Signal/ Frame Ground
11	PRT_RS232_RXD	Input	Output	Data Receive
12	PRT_RS232_TXD	Output	Input	Data Transmit
13	PRT_Status	Output	Input	Printer Ready
14	PRT_RS232_RTS	Output	Input	Handshake

Note 1: Pin 5 is isolated from pin 7 & 10 unless ground jumper is present

Note 2: Bezel illumination control jumper must be present for bezel modulation to be present on pin 9

Table 9: 14 Pin RS232 Serial Interface

2.2.2 Illuminated bezel interface

The table below describes the connection pin-out for the front Bezel Connector (3-pin “Molex” type).

Pin	Signal	Printer I/O
1	Bezel PWM	Output
2	24VDC	Output
3	GND	GND

Table 10: Bezel Interface

2.3 Printing Problems

The table below can be used to determine the cause and resolution of the most common problems that may occur. If the information in this section does not correct the problem, contact a Nanoptix service representative.

Problem	Possible Causes	What to Do
Printer Does Not Function When Turned On	Printer not plugged in	Check that printer cables are properly connected at both ends Check that the host and power supply are getting power
	Tray not fully closed	Close the tray
	Flat cable incorrectly or not fully inserted into the receptacle	Fully insert the flat cable in the into the receptacle at both ends
Paper jam	Paper width out of specification	Test paper width for compliance
	Debris or partial ticket stuck in the paper path	Open paper guide and detach roller, remove debris
	Paper's perforation burst strength out of spec	Test paper perforation for compliance
Noisy Feeder Motor (paper disengaged)	The printer is meant to be operated with paper engaged in the printing mechanism, failing to do so will cause gears to grind and slip, noise may result	Do not operate printer without any paper engaged in the printing mechanism Note: <u>Never</u> lubricate gears or any other part of the printer
Paper does not realign itself when a ticket is printed	Paper's alignment mark, (which is the black dot printed on the non-sensitive side of thermal paper) may be out of specification	The maximum reflectance of the alignment mark is 15% (infrared). Simply put, this means that the alignment mark's color should be an even/crisp black. If any white or gray is visible, it is an indication that the reflectance could be more than 15%
Line of print or section missing lengthwise on the entire ticket	Paper's thermal coating inconsistent	Change the paper stack to make sure the thermal coating is not the source
	Thermal printing mechanism damaged	Contact a customer service representative
The print is light or spotty	The thermal print head is dirty	Clean the print head by following the recommended procedure (Section 6)
	Paper's thermal coating inconsistent	Change the paper stack to make sure the thermal coating is not the source

Table 11: Troubleshooting Printing Problems

2.3.1 Main Controller PCB Connector Layout

A	TPH grounding tab
B	Feeder motor
C	Paper-in chute sensor & cover closed
D	Index (Top of Form)
E	Thermal Print Head
H	Paper low – bottom (one sheet)
I	Paper low – side (3 options)

Table 12: Connector Functions

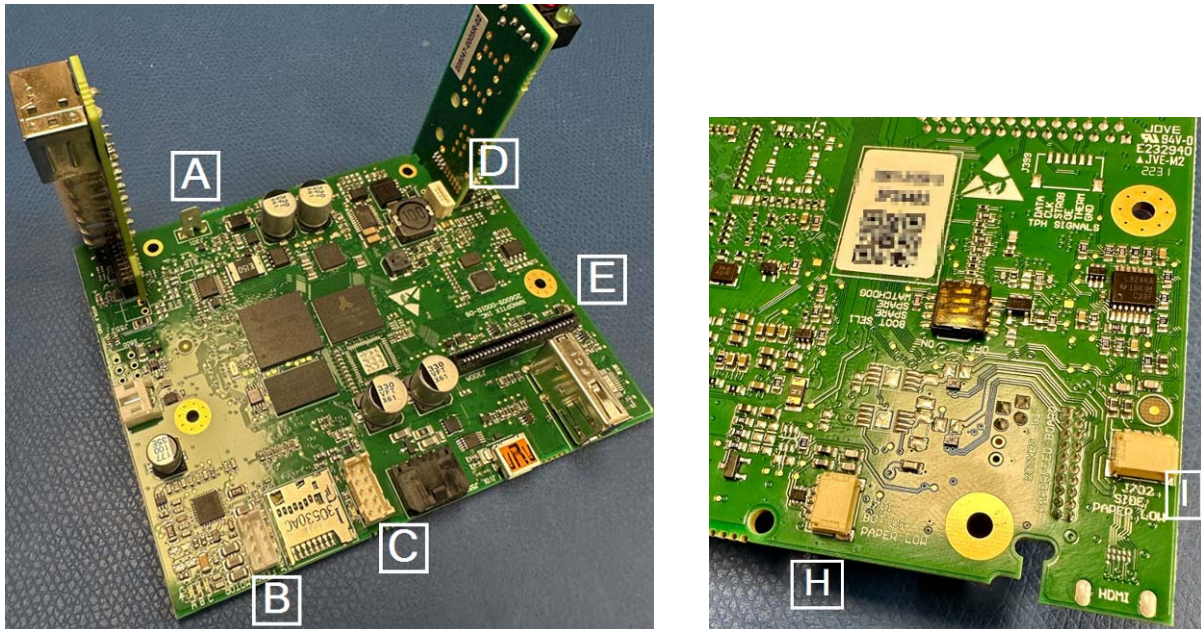

Figure 19: Connector Layout (Rev 2 shown)

3 Media and Supplies Guide

3.1 Thermal Paper Specifications

NOTE: Qualified thermal paper with the following specifications is required for proper operation.

Width	65 mm +/-1 (2.56 IN)
Length	156 mm +/- 1 (6.14 IN)
Thickness	4.5 +0.1 -0.3 mil
Brightness	89%
Smoothness	2000 sec Avg.
Perforation burst strength	1.3 +/- 0.4 LBS (0.59 +/- 0.18 Kg.
Alignment Mark (TOF)	Optical Density of 1.10 min.

Table 13: Paper Specifications

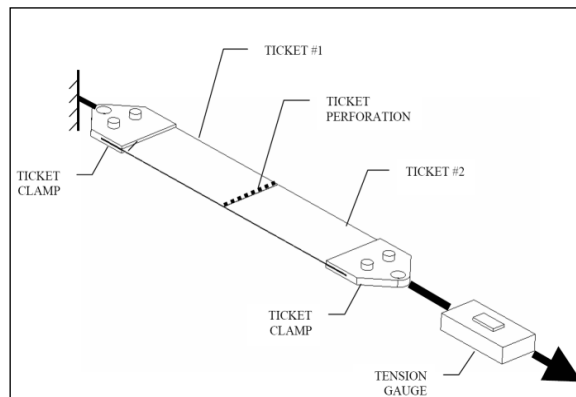

Figure 20: Perforation Test

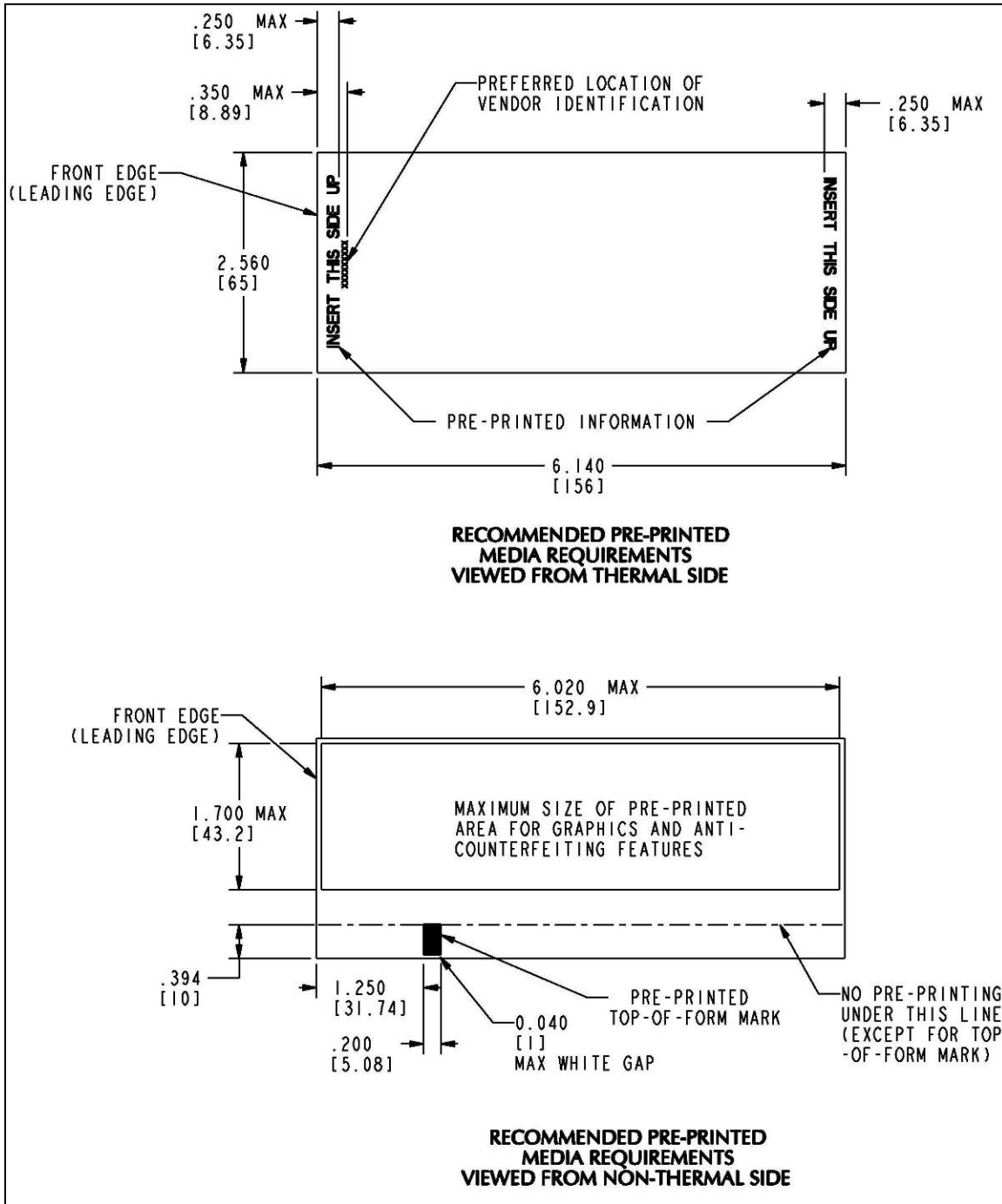

Figure 21: Ticket Specifications

3.2 Ordering Thermal Paper

The following paper grade produced by Appvion and Kanzaki Specialty Papers are recommended by Nanoptix. There are a number of paper converters qualified to supply this paper, provided they use the recommended grades listed in Table 14.

Paper qualification services are offered by Nanoptix for additional grades not listed below.

Manufacturer	Numbers	Nanoptix part no.	Paper Grade
Appvion Papers	Tel:920-991-8438	100505-3024R (200 stack) 100505-3025R (400 stack) 100505-3026R (600 stack) 100505-3027R (800 stack)	Royale 800-4.5
Kanzaki Specialty Papers (USA)	Tel:888-526-9254 Fax: 413-731-8864	100505-3012R (200 stack) 100505-3013R (400 stack) 100505-3014R (600 stack) 100505-3015R (800 stack)	TO-381-N
KANZAN Spezialpapiere GmbH	Tel: +49 2421 5924-0 Fax: +49 2421 5924-19	N/A	Kanzan KL 69

Table 14: Ordering Thermal Paper

3.3 Ordering supplies & cables

Contact your sales representative to order the communication cables listed in the table. The numbers are for reference only. Suppliers may use other numbers.

Part	Part Number
Power supply, 24 VDC	213005-0032R
Power cord (North America)	102080-0000R
Power cord (Europe)	102080-0001R
RS232 communication cable (14-Pin "Molex" type to DB-9)	210036-0004R
Second RS232 port, In-Line Cable	210036-0003R
USB Cable 2M (A to B)	100390-0001R

Table 15: Ordering supplies

3.4 Parts List (Available as a separate document)

ITEM #	PART NUMBER	DESCRIPTION	QTY
1	100041-0081R	SCREW, MACHINE, M2.5, 3MM	2
2	100041-1184R	SCREW, SEMS, M3, 6MM	10
3	100069-2007R	SPRING, BOTTOM PAPER PATH	1
4	100420-0000R	SENSOR, PAPER IN-CHUTE	1
5-1	208001-0011R	LED BOARD, BEZEL, GREEN	1
5-2	208001-0012R	LED BOARD, BEZEL, BLUE	1
5-3	208001-0015R	LED BOARD, BEZEL, RED	1
6	208032-0003R	TOP-OF-FORM, FLEX CIRCUIT	1
7-1	208047-0005R	PCB, VERTICAL, PAPER FEED	1
7-2	208047-0006R	PCB, VERTICAL, PAPER FEED, W/ ETHERNET	1
8	208049-0002R	PCB, VERTICAL, POWER	1
9	208051-0004R	SENSOR, PCB, PAPER-LOW	1
10	208063-0001R	SENSOR, PCB, LAST SHEET	1
11	209011-0105R	PCB, MAIN BOARD	1
12	210032-0009R	HARNESS, LED BEZEL BOARD	1
13	210087-0003R	HARNESS, SIDE PAPER-LOW SENSOR	1
14	210087-0005R	HARNESS, LAST SHEET SENSOR	1
15	210088-0001R	HARNESS, CHUTE SWITCH ASSEMBLY	1
16	300235-0001R	SPRING, LOCKING	1
17	300250-0006R	COVER PLATE, MAIN PCB	1
18	310019-0001R	PAPER GUIDE, BOTTOM	1
19	310023-0001R	HOLDER, SPRING, BOTTOM PAPER PATH	1
20	310027-0001R	HOLDER, COVER SWITCH	1
21	310088-0007R	FRAME, NEXTGEN	1
22	310089-0005R	MECH MOUNT BRACKET	1
23	310091-0006R	BASE PLATE	1
24	310092-0003R	PAPER TRAY	1
25	310094-0003R	LATCH, BASE PLATE RELEASE	1
26-1	310100-0002R	EXTENSION, PAPER TRAY, 800	1
26-2	310100-0003R	EXTENSION, PAPER TRAY, 600	1
27	310101-0001R	COVER, TRAY	1
28	310102-0004R	HANDLE	1
29	310105-0001R	ANTI-JAM MODULE, FACE	1
30	310106-0001R	HOLDER, TOP-OF-FORM SENSOR	1
31	310107-0003R	COVER, PAPER-LOW SENSOR	1
32	310109-0001R	ANTI-JAM MODULE, BASE	1
33	310110-0001R	TOP CHUTE COVER, ASSEMBLY	1
34	310118-0001R	HOLDER, BOTTOM PAPER CHUTE	1
35	310139-0001R	COVER, LAST SHEET SENSOR	1
36-1	310172-0001R	BEZEL, SHORT, BLUE	1
36-2	310172-0002R	BEZEL, SHORT, GREEN	1
36-3	310172-0003R	BEZEL, SHORT, RED	1
36-4	310172-0004R	BEZEL, SHORT, CLEAR	1
36-5	310173-0001R	BEZEL, LONG, BLUE	1
36-6	310173-0002R	BEZEL, LONG, GREEN	1
36-7	310173-0003R	BEZEL, LONG, RED	1
36-8	310173-0004R	BEZEL, LONG, CLEAR	1
37	310186-0001R	BLANKING PLATE	1
38	332400-0001R	MAGNET, BASE PLATE	1
39	340300-0306R	SCREW, THREADING, M3, 6MM	2
40	340300-0308R	SCREW, THREADING, M3, 8MM	2
41	340302-2208R	SCREW, THREADING, M2.2, 8MM	5
42	340302-2505R	SCREW, THREADING, M2.5, 5MM	1
43	340302-2508R	SCREW, THREADING, M2.5, 8MM	6
44	340400-0001R	RETAINER RING	1
45	375007-0002R/0003R	PRINT MECHANISM	1

Figure 22: Part List

3.5 Exploded View (Available as a separate document)

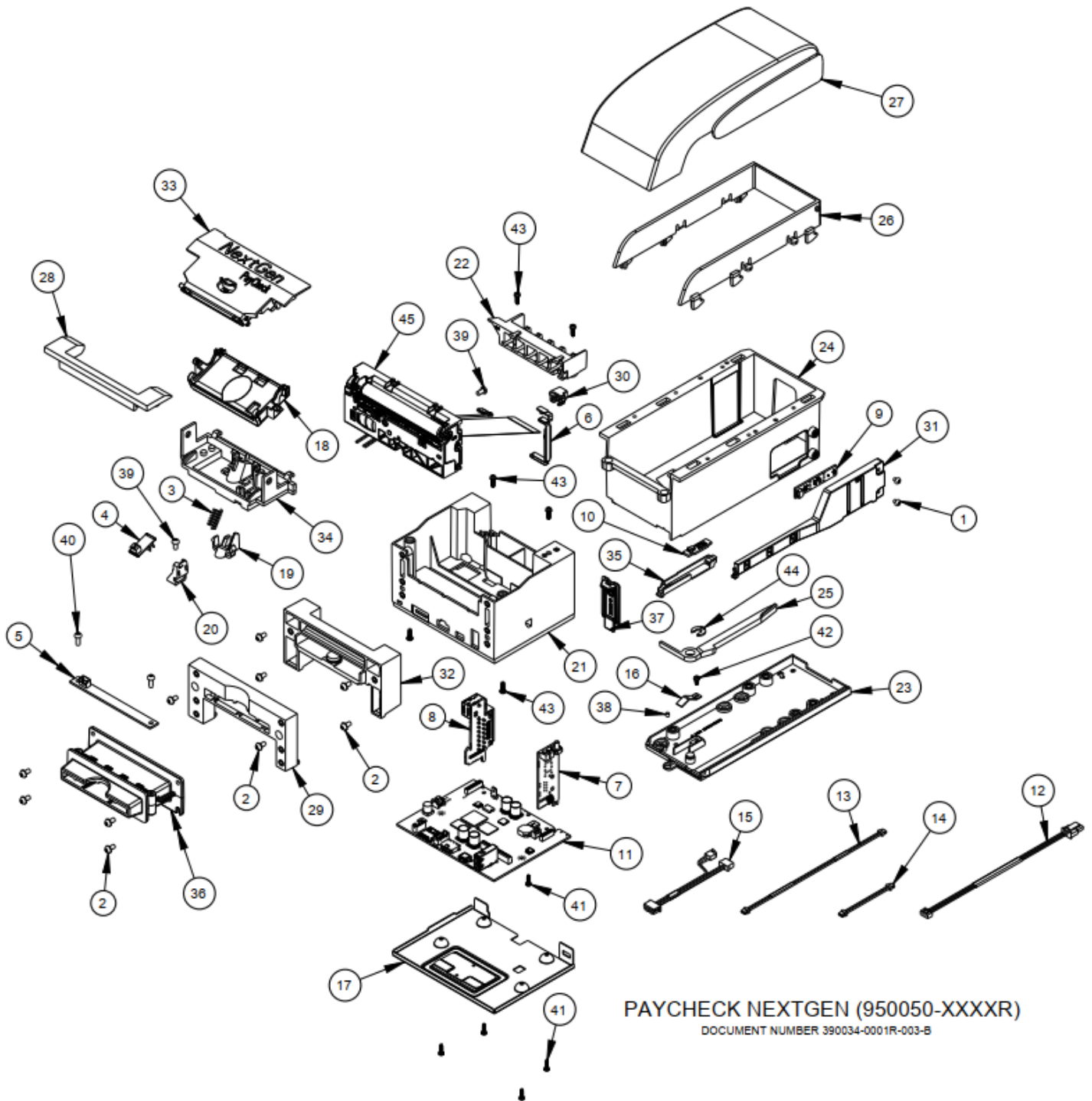

Figure 23: Exploded View

3.6 Mechanical Drawings

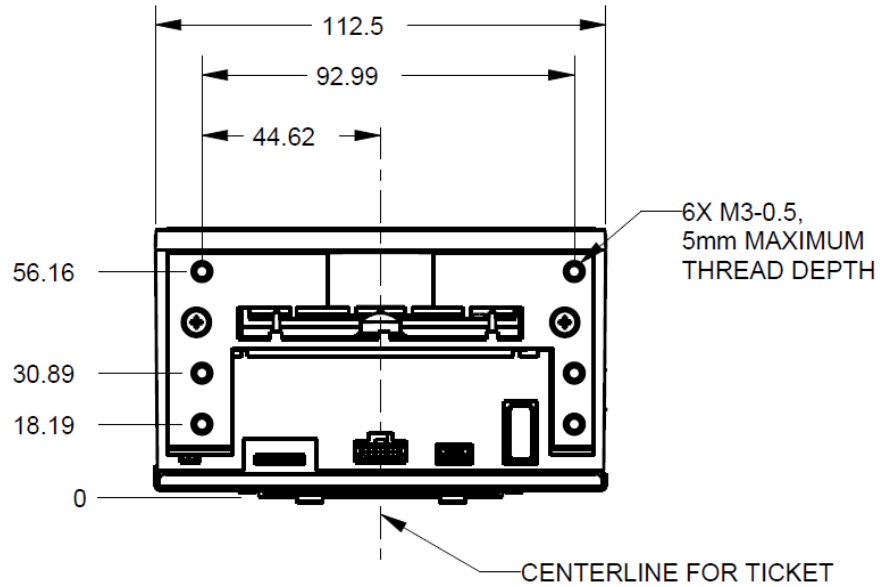

Figure 24: Dimensions - Front

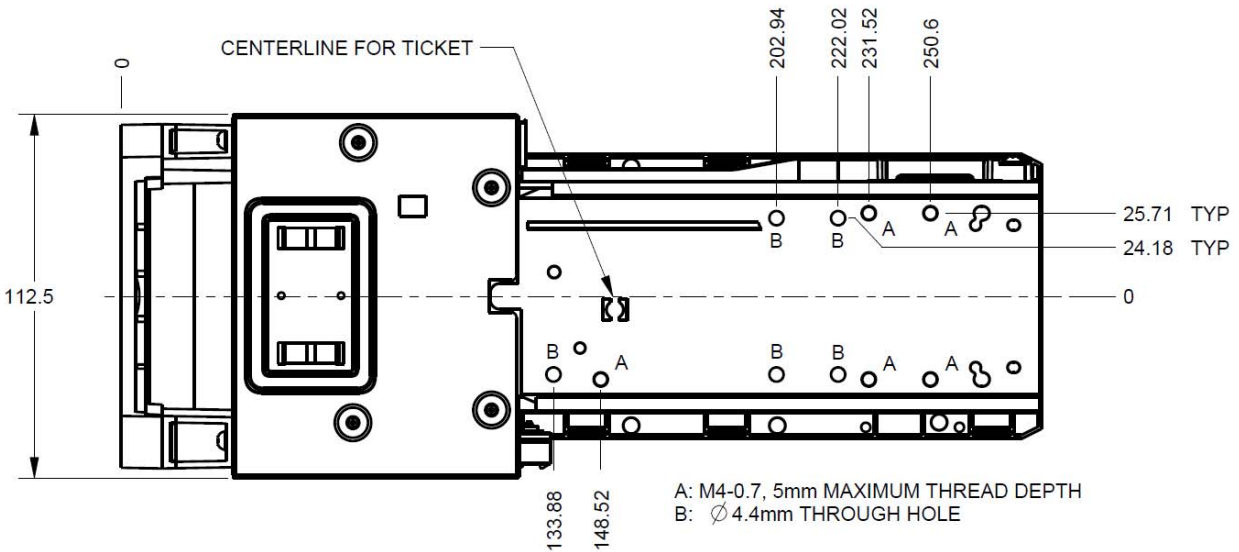

Figure 25: Dimensions - Bottom

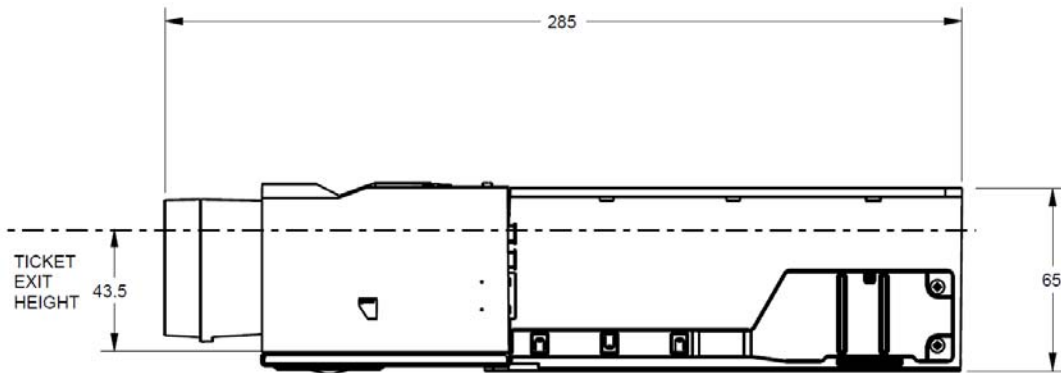

Figure 26: Dimensions – Right side (no ticket extension)

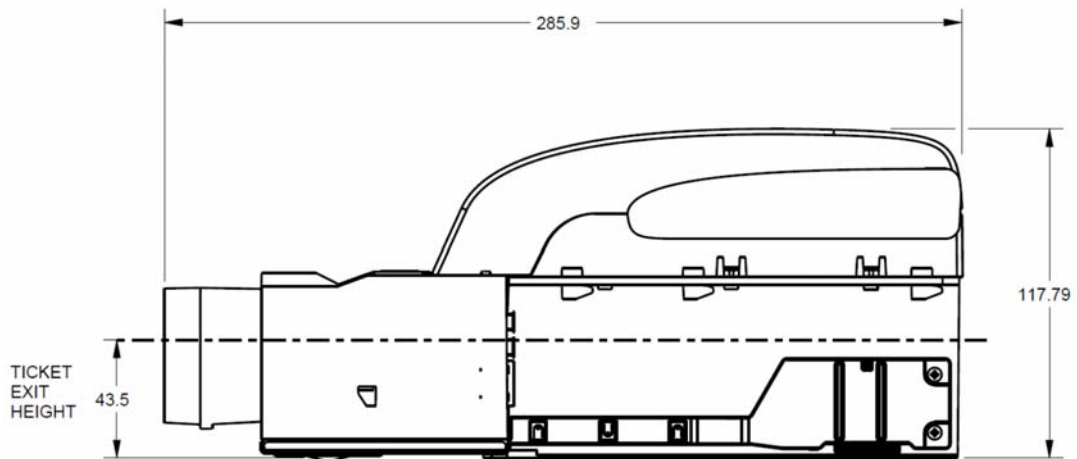

Figure 27: Dimensions – Right side (600 ticket extension)

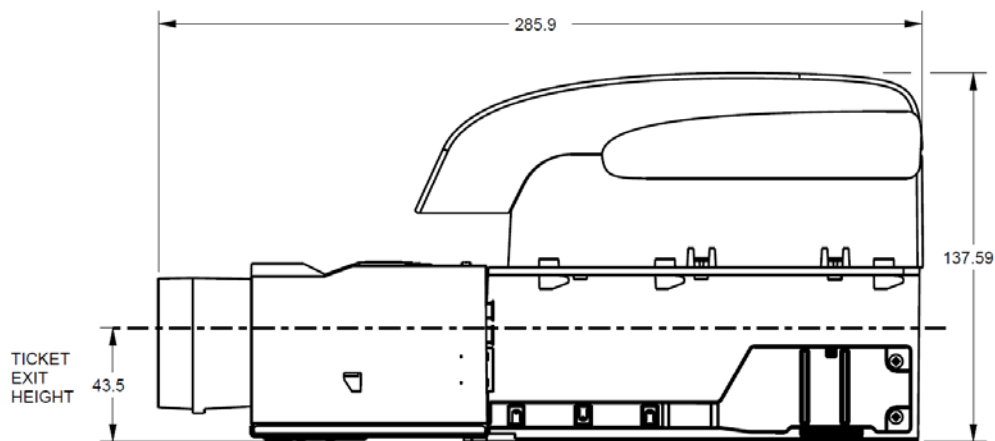

Figure 28: Dimensions – Right side (800 ticket extension)

4 Spare parts replacement instructions



Use ESD protection (such as a wrist strap) anytime a PCB is exposed



Instruction A: Removal of the printer from the mounting bracket

1. Pull printer forward until resistance is felt, then move green lever all the way to the left
2. Pull printer further forward to separate from mounting bracket

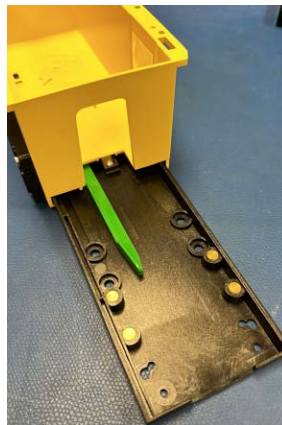

Figure 29: printer mount

Instruction B: Removal of jam proof module

1. Remove 2 screws to remove the outer jam proof module
2. Remove 6 screws to remove the inner jam proof module



Figure 30: Jam Proof module

Instruction C: Removal of the base plate

1. Remove 4 screws then lift up to remove the baseplate

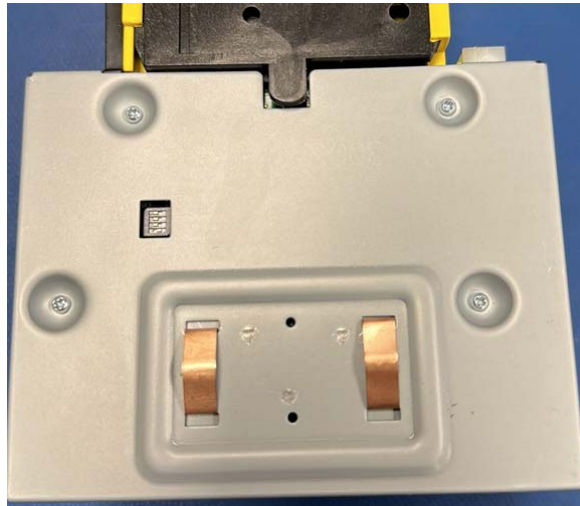

Figure 31: Base Plate

Instruction D: Removal of the circuit boards

1. Disconnect the 2 paper low harnesses
2. Lift board and disconnect the remaining harnesses
3. The 2 auxiliary boards are removed by lifting up

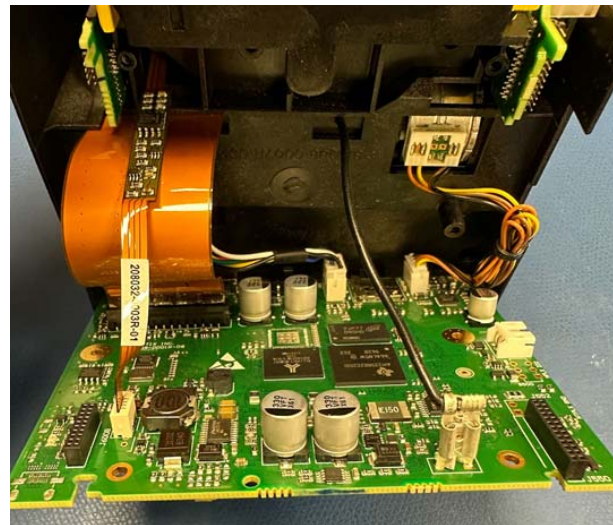

Figure 32: Circuit boards

Instruction E: Removal of ticket inlet & Index mark (TOF) sensor

1. Remove 2 mounting screws and lift ticket inlet
2. Remove the sensor by pushing out the sensor holder

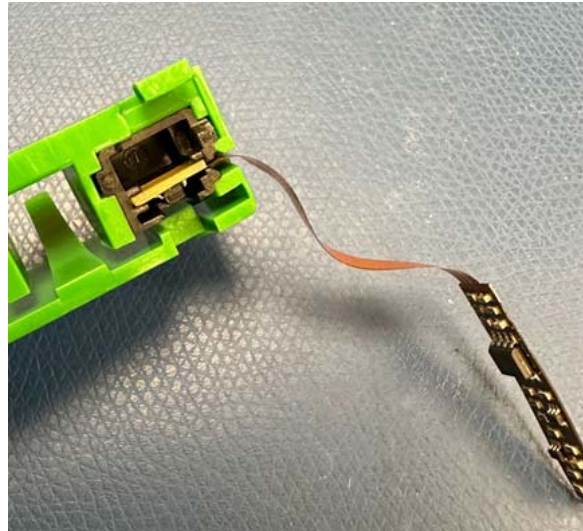
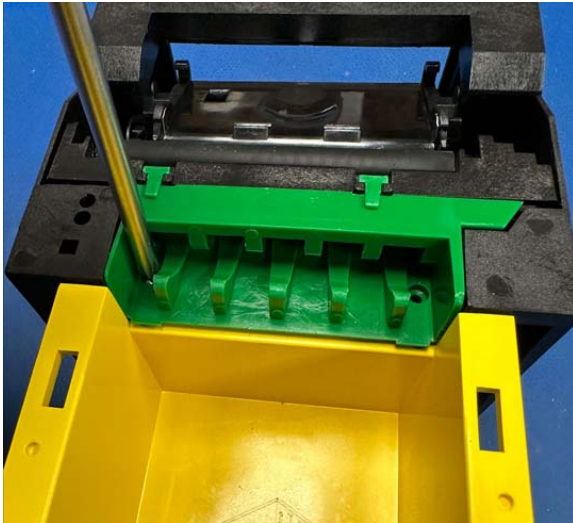

Figure 33: Ticket Inlet & Index sensor

Instruction F: Removal of ticket tray

1. Remove 2 mounting screws and lift ticket tray



Figure 34: Ticket Tray

Instruction G: Removal of front bar

1. Remove 2 mounting screws and lift bar

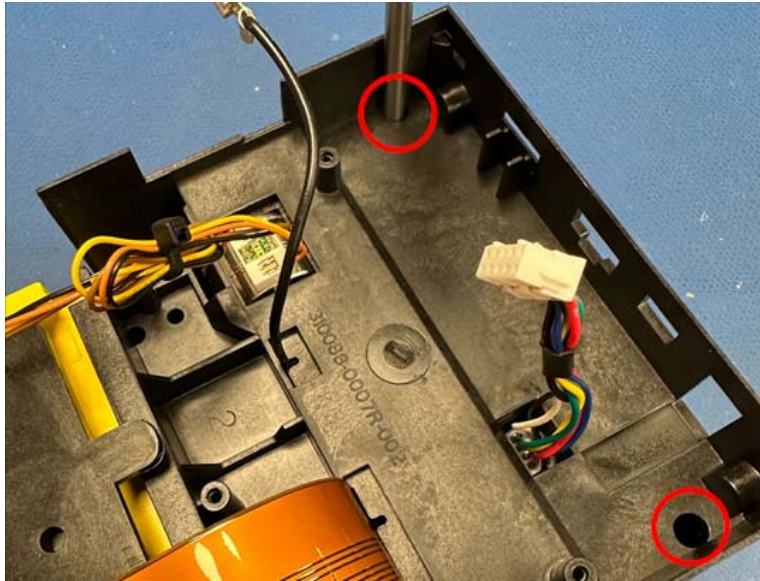

Figure 35: Front bar

Instruction H: Removal of printing mechanism assembly

1. Lift assembly up while guiding harnesses through their corresponding access holes

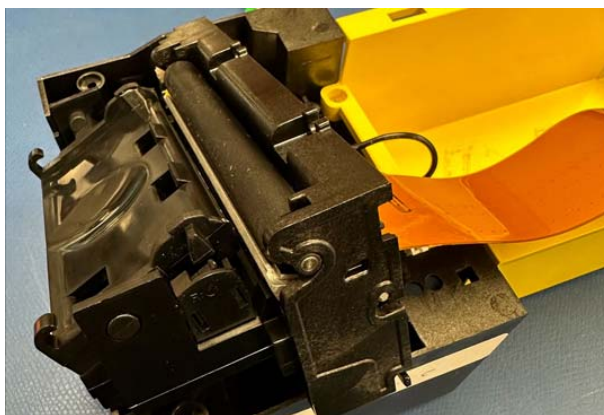

Figure 36: Printing Mech

Instruction I: Removal of the paper guide assembly

1. Remove the mounting screw then slide the guide assembly up and away from the printing mechanism



Figure 37: Paper guide

Instruction J: Removal of the top paper guide from the assembly

1. Push out on both lower paper guide tabs at the same time while sliding the top paper guide forward.

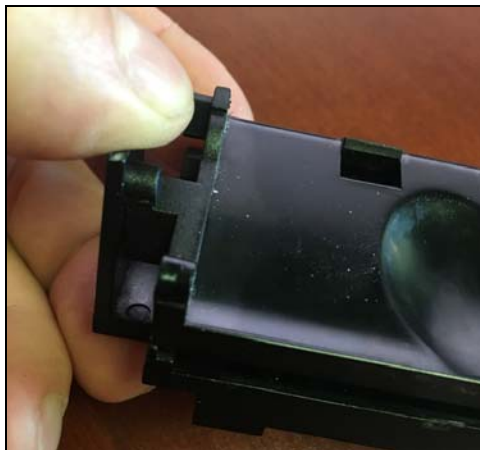

Figure 38: Top paper guide

Instruction K: Removal of chute sensor

1. Push front sensor mounting clip then lift sensor up.

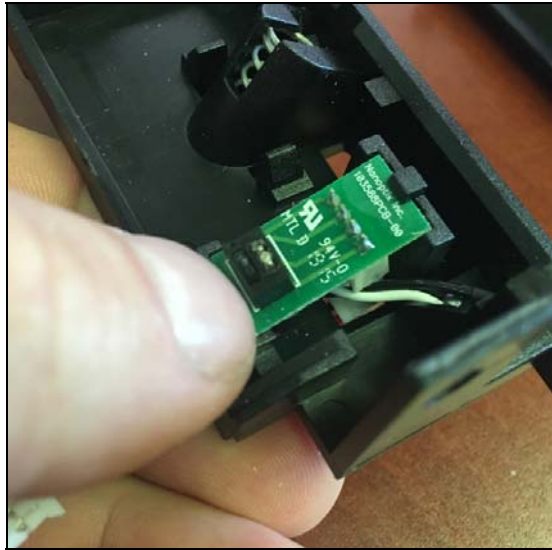

Figure 39: Chute sensor

Instruction L: Removal of the paper guide switch assembly

1. Remove mounting screw and lift up the assembly up

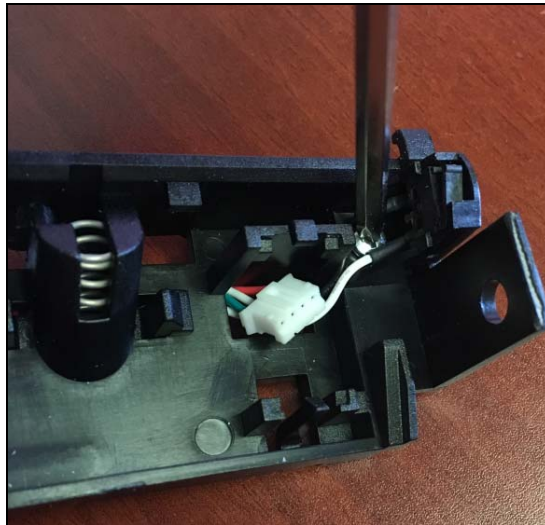

Figure 40: Guide switch

5 Printer Maintenance Instructions

Note: Under normal operating conditions, the minimum interval for cleaning the Nanoptix PayCheck[®] NextGen[™] printer is *3 months* or *5 km* of paper printed, whichever comes first.

1. Remove excess dust using a portable vacuum cleaner or wipe clean with a damp cloth



Figure 41: Remove excess dust

2. Remove top paper guide by pressing on the yellow clip and lifting up. Then pull forward to unhinge.



Figure 42: Remove top paper guide

3. Remove roller by pressing down and rolling towards the front of the printer

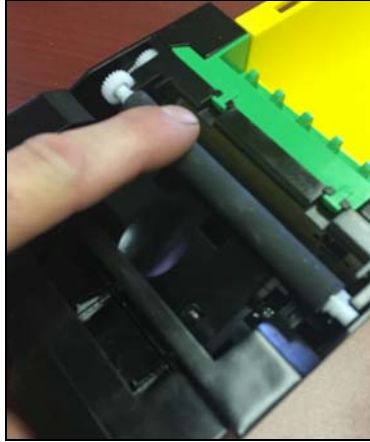

Figure 43: Remove Roller

4. Clean the roller with a cotton swab and a mild soap solution.



Figure 44: Clean Roller

5. Clean paper guide sensor using a cotton swab



Figure 45: Clean paper guide sensor using a cotton swab

6. Clean the heating elements (black line on the print head) with a cotton swab and isopropyl alcohol.

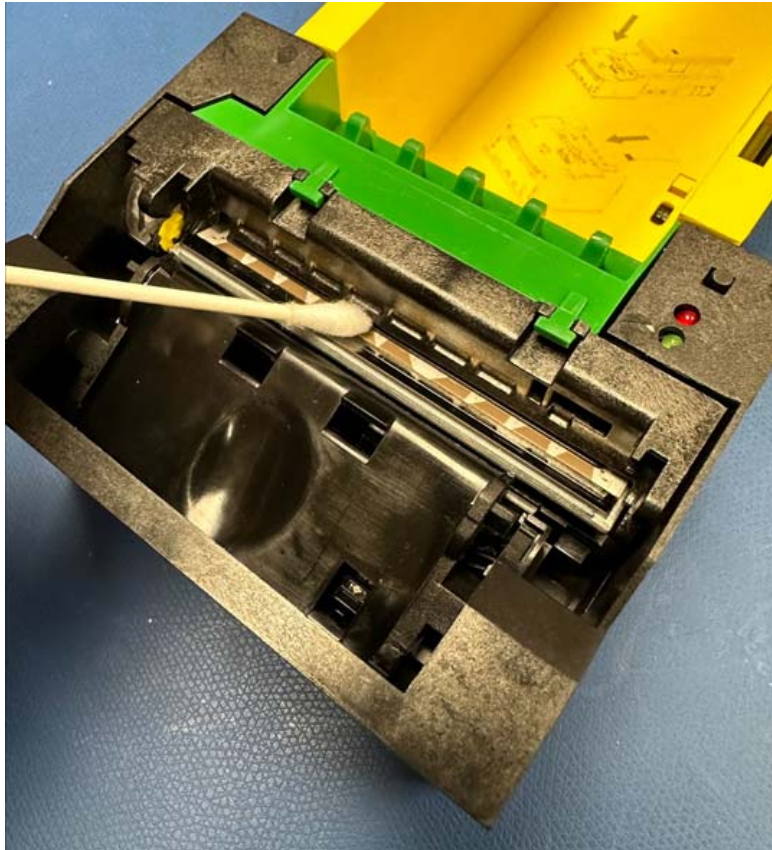

Figure 46: Clean heating elements

6 Service & Support

6.1 Returning printers back to Nanoptix for repairs (RMA)

- Send repair approval request to Nanoptix Inc. which should include:
 - Printer model #
 - Serial #
 - Brief problem description
- Ship defective products to Nanoptix Inc.
- Ensure that each package being sent is identified by the specified RMA number

NOTE: Make sure to place a blank ticket or a piece of paper between the thermal print head and roller for shipping and storage.

RMA # XXXXXX
Nanoptix Inc.
699 Champlain St.
Dieppe, NB, Canada
E1A 1P6

NOTE: It is imperative to have every package clearly identified by an RMA number.

6.2 Technical Support Contact Information

Service department
Nanoptix Inc.
699 Champlain St.
Dieppe, NB, Canada
E1A 1P6
Tel: +1.506.384.3388
Fax: +1.506.384.3588
E-mail: service@nanoptix.com
Web site: www.nanoptix.com